

MIC-770 V3

Compact Fanless System with 12th Gen Intel® Core™ i CPU Socket (LGA 1700)

Preliminary



Features

- Intel® 12th Gen Core™ i CPU socket-type (LGA1700) with Intel® R680E/H610E chipset
- Wide operating temperature (-20 ~ 60 °C)
- VGA and HDMI output
- 2 x GigaLAN, 2 x USB 3.2 (Gen2) and 6 x USB 3.2 (Gen1)
- 2 x RS-232/422/485 and 4 x RS232 serial ports (Optional)
- 1 x 2.5" HDD/SSD, 1 x mSATA, and 1 x NVMe M.2
- 9 ~ 36 V_{DC} input power range
- IP40 dust proof for deployment in harsh environment
- Supports FlexIO and iDoor technology, flexible configure additional HDMI, DP, DVI, COM port, DIO, Remote switch IO
- Supports Advantech i-Modules
- Supports Advantech SUSI-API and embedded software APIs
- Supports Intel® vPro™/AMT and TPM technologies
- Supports Advantech iBMC 1.2 remote out-of-band power management solution on DeviceOn



Specifications

	CPU	i9-12900TE	i7-12700TE	i5-12500TE	i3-12100TE	Pentium G7400TE	Celeron G6900TE
12 th Generation Processor (TDP 35W)	Core/Thread number	16/24	12/20	6/12	4/8	2/4	2/2
	Base Frequency	1.10 GHz	1.40 GHz	1.90 GHz	2.10 GHz	3.00 GHz	2.4 GHz
	Max Turbo Frequency	4.80 GHz	4.60 GHz	4.30 GHz	4.00 GHz		
	L3 Cache	30 MB	16 MB	12 MB	6 MB	2.5MB	2.5MB
	Temperature	-20 ~ 60 °C (w/ industrial wide-temp SSD, 0.7m/s air flow)					
	Chipset	R680E/H610E					
	BIOS	AMI 256Mb/128Mb SPI Flash					
	12 th Generation Processor (TDP 65W)	CPU	i9-12900(E)	i7-12700(E)	i5-12500(E)	i3-12100(E)	G7400E (46W)
Core/Thread number		16/24	12/20	6/12	4/8	2/4	2/2
Base Frequency		2.30 GHz	2.10 GHz	2.90 GHz	3.20 GHz	3.60 GHz	3.00 GHz
Max Turbo Frequency		5.00 GHz	4.80 GHz	4.50 GHz	4.20 GHz		
L3 Cache		30 MB	25 MB	18 MB	5 MB	2.5 MB	2.5 MB
Temperature		-20 ~ 50 °C (w/ industrial wide-temp SSD, 0.7m/s air flow)					
Chipset		R680E/H610E					
BIOS		AMI 256Mb/128Mb SPI Flash					
Memory	Technology	Dual-channel DDR5 4800 MHz (R680E SKU supports ECC)					
	Socket	2 x 262-pin DDR5 SODIMM (up to 32GB per socket)					
Maximum Capacity	64GB						
	Chipset	Core i: Intel® UHD Graphics 770 Pentium/Celeron: Intel® HD Graphics 710					
Display	VGA	1 x DB15, up to 1920 x 1200 maximum resolution					
	HDMI	1 x HDMI, up to 4096 x 2160@30Hz					
	Multiple Display	R680E: 4 x independent displays (third and fourth display output via optional cable) H610E: 3 x independent displays (third display output via optional cable)					
	Ethernet	Controller	R680E LAN1: Intel® i219LM, LAN2: Intel® i210IT H610E LAN1: Intel® i219V, LAN2: Intel® i210IT				
Storage	Interface	2 x RJ45					
	HDD	1 x 2.5" HDD/SSD (up to 2 x 2.5" SSD by optional kit; 2 x 3.5" HDD by i-Module)					
	mSATA	1					
	NVMe M.2	1 x M Key Z280 with PCIe Gen 4 x 4 (R680E SKU, operating temp. -20 ~ 50 °C)					
I/O	RAID	0/1/5/10 (R680E SKU only)					
	USB	R680E: 2 x USB3.2 (Gen2), 6 x USB3.2 (Gen1), 1 x USB 2.0 (Internal) H610E: 4 x USB3.2 (Gen1), 4 x USB2.0					
	Serial Port	2 x DB9, RS-232/422/485 support auto flow control; 4 x RS-232 (Optional)					
	Audio	2 (1 x line out and 1 x mic in)					
Expansion	Module	Supports Advantech i-Modules					
	Mini PCIe/mSATA	R680E: 1 x mini PCIe, 1 x mini PCIe/mSATA H610E: 1 x mini PCIe, 1 x mSATA					
LED and Switch	LED	2 (1 x Storage and 1 x Power), 4 for COM1 TX/RX and COM2 TX/RX					
	Button	1 x Power on/off switch					
	Remote Switch	Yes, 2pin terminal block (Optional)					
Power	Type	ATX/AT					
	Input Voltage	9 ~ 36 V _{DC}					
	Power consumption	9~19V _{DC} support total 140W 19~36V support total 180W for system and Peripheral card					
Watchdog Timer	Output	System reset					
	Interval	Programmable 1 ~ 255 sec/min					
	Temperature	65W CPU w/ industrial wide Temp. SSD		35W CPU w/ industrial wide Temp. SSD		Non-operating	
Environment	Humidity	-20 ~ 50 °C with 0.7 m/s air flow					
	Vibration	95% @ 40 °C (non-condensing)				-20 ~ 60 °C with 0.7 m/s air flow	
	Shock	With SSD: 3 Grms @ 5 ~ 500 Hz, random, 1 hr/axis With 2.5" HDD: 1 Grms @ 5 ~ 500 Hz, random, 1 hr/axis				2G	
	Shock	With SSD: 20G, IEC-68-2-27, half-sine wave, 11 ms duration				50G 11 ms	
	Dimensions (W x H x D)	77 x 192 x 230 mm (3.07" x 7.55" x 9.05")					
Mechanical	Weight	2.8 kg (6.17 lbs)					
	Installation	Desktop/wall mount					
	EMC	CE/FCC Class A, CCC, BSMI					
Certifications	Safety	CB/UL, CCC, BSMI					
	OS Support	Windows 10, Windows 10 IoT, Linux OS					

Note: The CPU PCIe slot can support graphic cards only due to Intel design specification. Other types of add-on cards will have no function installed on this slot.

Dimensions

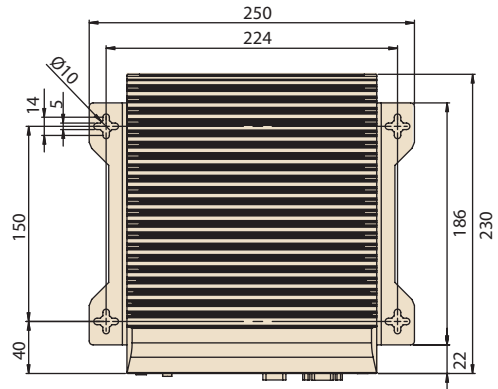
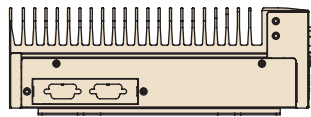
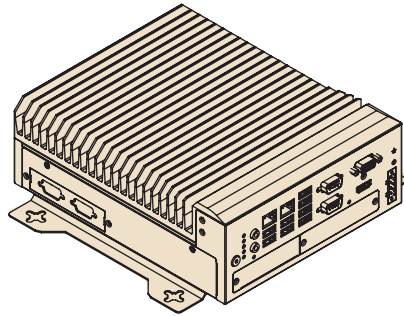

Unit: mm

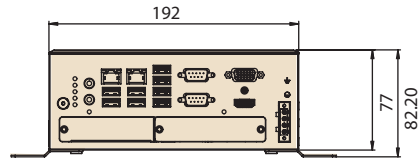

Front View

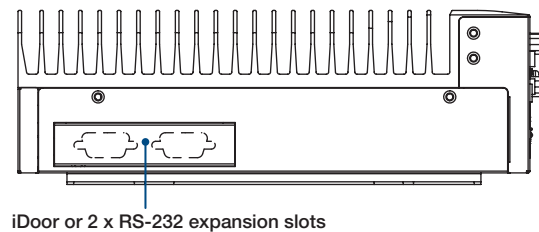
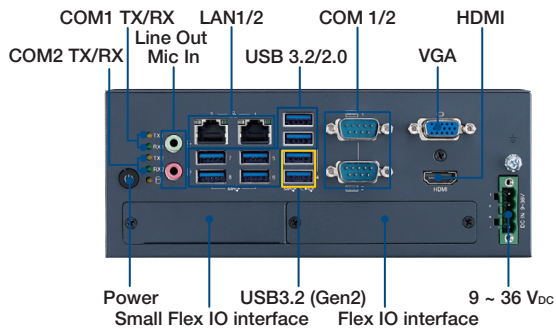

Ordering Information

Part Number	VGA	HDMI	2.5" HDD/SSD	mSATA	NVMe M.2	USB3.2 (Gen2)	USB3.2 (Gen1)	USB 2.0	GbE	COM	PCIe	Power
MIC-770V3W-00A1	1	1	1	1	1	2	6	0	2	2, up to 6 (Optional)	i-Module (optional)*	9 ~ 36V _{DC}
MIC-770V3H-00A1	1	1	1	1	0	0	4	4	2	2, up to 6 (Optional)	i-Module (optional)*	9 ~ 36V _{DC}

* MIC-770V3H does not support MIC-75M20-01

Packing List

Part Number	Description	Quantity
MIC-770 V3	MIC-770 V3 bare system	1
2041077040	MIC-770 V3 startup manual (ENG+TC+SC)	1
1652003234	4-pin Phoenix power connector	1
1960070543T005	2 x Mounting bracket	2
1700013095-01	SATA cable	1
1700024372-01	SATA power cable	1
2170000093-01	CPU thermal grease	1
1990019498N000	RAM thermal pad	2

Optional i-Modules*

Part Number	Description
MIC-75M13-00A2	4-slot expansion module (1 x PCIe and 3 x PCI slots)
MIC-75M20-00C1	2-slot expansion module (2 x PCIe slots)
MIC-75M20-01A2**	2-slot expansion module (2 x PCIe slots)
MIC-75M11-00A2	2-slot expansion module (1 x PCIe and 1 x PCI slots)
MIC-75S20-00A2	2-slot expansion and storage module (2 x PCIe and 2 x 2.5 removable 2.5" storage bay)
MIC-75G20-10B1	GPU Card expansion module (2 x PCIe and 2 x removable 2.5" storage bay)
MIC-75G30-00B1**	Dual GPU card expansion module (3x PCIe and 2 x removable 2.5" storage bay)
MIC-75GF10-00A1	MXM GPU expansion i-Module (1 x PCIe and 2 x removable 2.5" storage bay)
98R17520301	2 x 3.5" HDD kit

*Please refer to i-Module datasheet for more detail.

** R680E SKU only

Embedded OS

Part Number	Description
TBD	TBD

Optional Accessories

Part Number	Description
Adaptor	
96PSA-A230W24P4-3*	ADP A/D 100-240V 230W 24V C14 TERMINAL BLOCK 4P
1702002600	Power cord (USA) UL/CSA, 3-pin, 10A, 125V, 1.83 M, 180 D
1700008921	Power Cord PSE 3P 7A 125V 183cm
1702002605	Power Cord (EU), 3-pin, 10A, 250V 1.83M, 90D
Din Rail PSU	
96PSD-A240W24-MN*	A/D 100-240V 240W 24V NDR DIN RAIL
1700031170-01	DC-DC power cord, A cable TEM*4/TEM*4 UL2464 18AWG 150cm
1700029720-01	AC-DC power cord (US), M cable AC CONN 3P 183cm
1700030520-01	AC-DC power cord (CN), M cable conn 3P CCC 10A 250V 150cm
1700031408-01	AC-DC power cord (EU), M cable conn 3P/G-TEM*3 80CM

* Please use 230W adaptor when i-Module is added.

Note:

- MIC-770 V3 supports Advantech iDoor modules (both MOS and PCM series), excluding the PoE model.
- The **PCM** series module requires a bracket (P/N: **1960065854N001**) that must be ordered separately.

Optional Flex I/O* & Kits

Part Number	Description
Flex I/O	
AIIS-DIO32-00A1E**	AIIS GPIO module (32 bit)
PCA-TPMSPI-00A1	TPM 2.0 module (SPI)
98R17500001	MIC DVI FIO
98R17500101	MIC HDMI/Remote power on/off FIO
98R17500301	MIC HDMI kit FIO
98R17500401	MIC Remote power on/off FIO
98R17500601	MIC 2x COMports kit FIO
98R17500701	MIC Remote power on/off kit for SFIO
98R17500801	MIC Reset/Remote power on/off/5VDC kit FIO
98R17500901	MIC GPIO kit FIO
98R17501001	MIC DP kit FIO
98R17501101	COM and HDMI kit
Advanced Flex I/O***	
98910770301	MIC NVMe + 4 LAN Advanced FIO
98910770401	MIC NVMe Advanced FIO
98910770501	MIC 4 PoE Advanced FIO
Storage Kit	
98R1752010E	2nd 2.5" HDD/SSD kit (used in 2-slot i-Module)
98R1752020E	2 x 2.5" SSD kit (Thickness: 7mm)
Mounting Kit	
98R17500210	MIC Din Rail Mounting kit
98R17500501	MIC Wall Mounting kit

* Please refer to Flex I/O datasheet for more detail.

** AIIS-DIO32 requires a DB37 bracket (P/N: 1960068787N002)

*** R680E SKU only